

WARNING BEACON LED - $\varnothing 130\text{mm}$

SPECIFICATIONS

- Voltage: 12-24V
- Color LED: amber
- Flashing pattern: 6 patterns
- Approval: ECE R65 / RoHS
- Ingress protection (IP rating): IP 65
- Installation: flat base/screw mount
flex mount
magnetic base
magnetic base + integrated battery

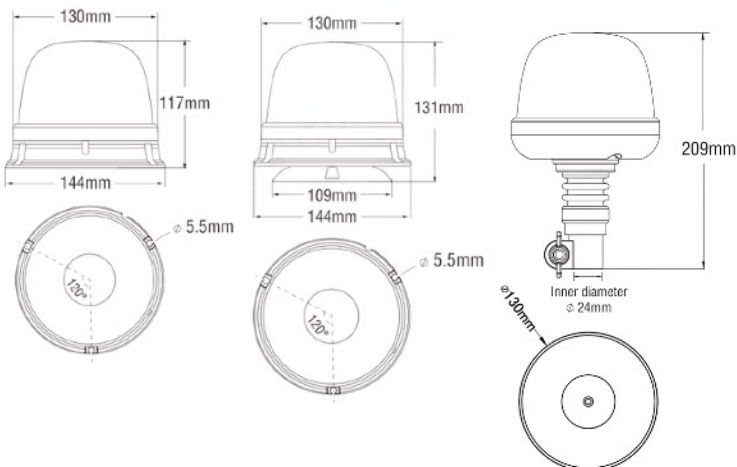

Charging with included 2-pole (cigar plug) cable



MAGNETIC BASE WITH INTEGRATED BATTERY AND REMOTE CONTROL

MAGNETIC BASE

FLAT BASE

PART NUMBER	INSTALLATION	VOLTAGE	INGRESS PROTECTION	FLASHING PATTERNS	APPROVAL
EBL57801	flat base/screw mount	12-24V	IP65	6 flashing patterns	ECE R65 RoHS
EBLM57803	magnetic base				
EBLB57808	magnetic base + battery + remote control				
EBLF57805	flex base				